

"DANE-HOT"

WOLTMAN STYLE WATER METERS

MODEL: "DANE" FLANGED HOT WATER WITH REED SWITCH PULSE OUTPUT

APPLICATION:

Accurate measurement of the volume of hot & cold water passing through the water meter.



Features:

- Removable element for simple maintenance,
- Sealed register,
- Long term clear reading display,
- Magnetic transmission,
- Low resistance,
- Reliable action,
- Low pressure loss,
- Long working life.

Operating Conditions:

Water Temperature: Hot & Cold water to 90 degrees C.

Maximum Pressure: 16 Bar (1,600 kPa) maximum operating pressure includes pressure surge conditions.

Installation to be horizontal with the display dial uppermost,

Maximum permissible error:

In the lower zone from Q_{min} inclusive up to but excluding Q_t is +/- 5%

In the upper zone from Q_t inclusive up to and including Q_s is +/- 2%

NOTE:

Technical data conforms to International Standard ISO4064 and Australian Table D Flange dimensions. Dials display total flow of water in cubic meters plus rotating needle dials for 1, 10, 100 and 1000 litres.

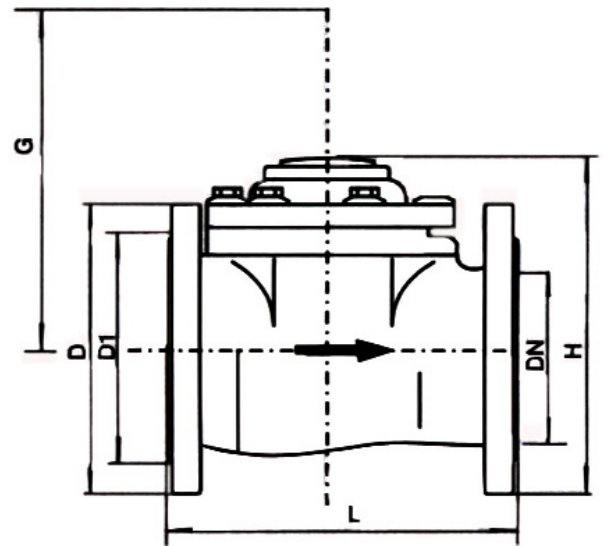

Main technical information and data

DANE Meter Model	Size mm	Class	q_s	q_p	q_t	q_{min}	Min. Reading	Max. Reading
			Max Flow	Nominal Flow	Transitional Flow	Min. Flow		
			m ³ /h				m ³	
DANE-50-W-AC	50	A	30	15	4.5	1.2	0.01	999999
		B			3.0	0.45		
DANE -65-W-AC	65	A	50	25	7.5	2.0	0.01	999999
		B			5	0.75		
DANE -80-W-AC	80	A	80	40	12	3.2	0.01	999999
		B			8.0	1.2		
DANE -100-W-AC	100	A	120	60	18	4.8	0.01	999999
		B			12	1.8		
DANE -125-W-AC	125	A	200	100	30	8	0.01	999999
		B			20	3		
DANE -150-W-AC	150	A	300	150	45	12	0.1	9999999
		B			30	4.5		
DANE -200-W-AC	200	A	500	250	75	20	0.1	9999999
		B			50	7.5		
DANE -250-W-AC	250	A	800	400	120	32	1	99999999
		B			80	12		
DANE -300-W-AC	300	A	1200	600	180	48	1	99999999
		B			120	18		
DANE -400-W-AC	400	A	2000	1000	300	80	1	99999999
		B			200	30		
DANE -500-W-AC	500	A	3000	1500	450	120	1	99999999
		B			300	45		

Flow error curve

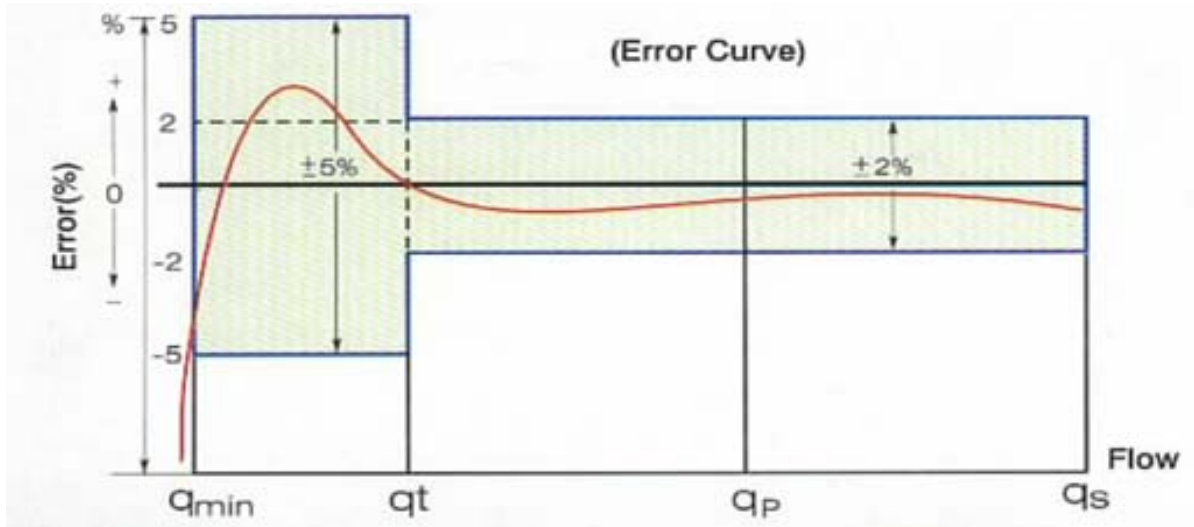

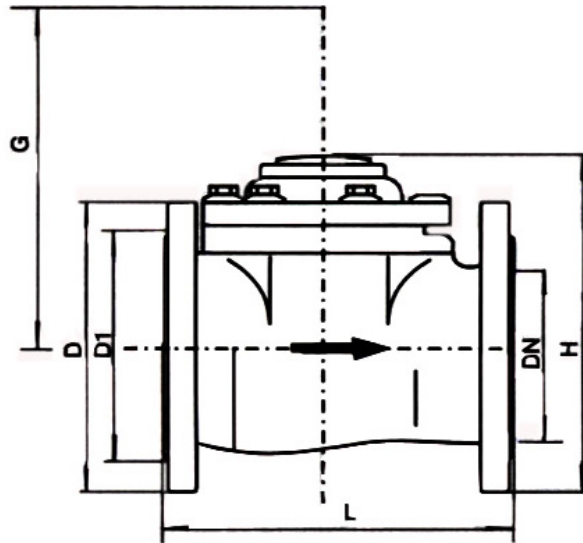

Dimensions and weights

Dane Meter Model.	Size.	Length.	Height.	G Dim.	Connecting flange			Weight kg
					mm			
					D Outer diameter.	D1 Bolt circle diameter.	Connecting Bolts	
DANE -50-W-AC	50	200	232	360	165	114	4-M16	12
DANE -65-W-AC	65	200	242	360	185	127	4-M16	13
DANE -80-W-AC	80	225	252	360	200	146	4-M16	16
DANE -100-W-AC	100	250	262	360	220	178	4-M16	18
DANE -125-W-AC	125	250	275	360	250	210	8-M16	20
DANE -150-W-AC	150	300	325	420	285	235	8-M16	42
DANE -200-W-AC	200	350	352	420	340	292	8-M16	64
DANE -250-W-AC	250	450	470	660	395	356	8-M20	94
DANE -300-W-AC	300	500	492	660	445	406	12-M20	114
DANE -400-W-AC	400	600	631	750	565	521	12-M24	199
DANE -500-W-AC	500	800	740	840	620	641	16-M24	340

NOTE: The flange dimensions are for Australian Table D.

Installation:

- All "DANE" meters must be installed horizontally with the reading dial uppermost,
- The meter must be installed so that it remains full of water at all times,
- On installation, fill the pipework and the water meter slowly to avoid damaging the equipment with a high water and air surge,
- Install an isolation valve before and after the water meter to allow for maintenance,
- Install the meter with straight pipe lengths before and after the meter, (10 x the diameter of straight pipe before and, 5 x the diameter of straight pipe after the meter),
- Install a coarse filter prior to the meter to protect the meter against damage caused by fast moving foreign objects, grit, sand etc.
- Install pressure surge protection valves on the system to eliminate over-pressure.

Flow V's Pressure / Head Loss Chart

Head loss is in
m of head

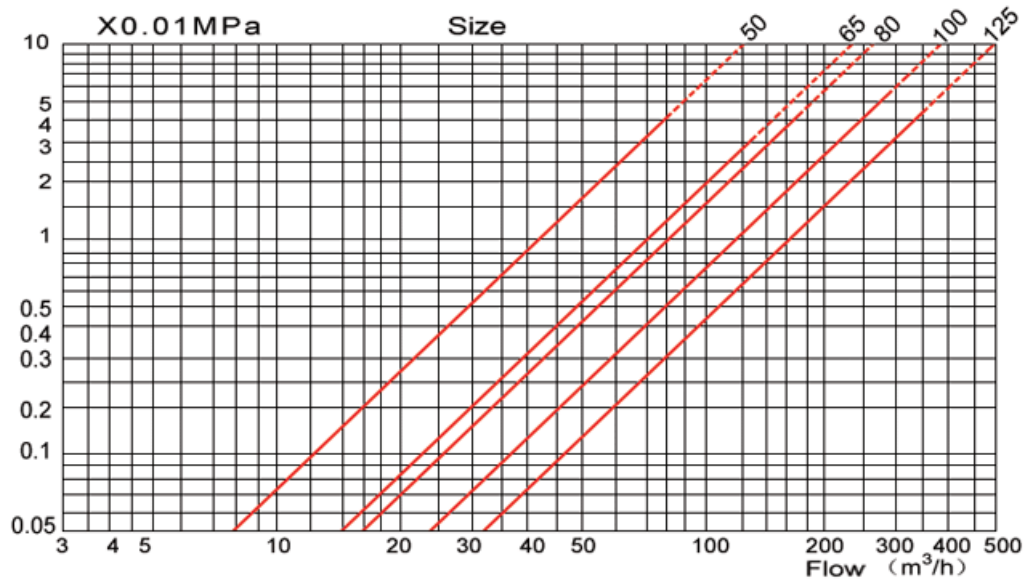

Head loss is in
m of head

